

ARJ45® Category 7a Connectors



Stewart Connector

ARJ45® Category 7a Connector System

Features / Benefits

- Meets IEC 60603-7-7 standard for Category 7 performance up to 600 MHz
- Meets the proposed Category 7a standard for increased frequency up to 1000 MHz
- Meets the interface for Category 7 connectors as defined by IEC 60603-7-7
- Interface compatible with the Nexans' GG45 Category 7 connectors
- Right angle PCB jack available for Category 7a patch panel designs and high speed data transmission applications
- Uses data transmission pair isolation techniques to achieve high frequency performance up to 1000 MHz
- Plug design includes a built-in strain relief boot as well as an anti-snap feature for plug tab protection
- UL 94-V0 plastic components
- Wave solder compatible
- RoHS complaint

ARJ45® Jack	
Part Number	Description
SS-77100-004	Single port, horizontal, and shielded
ARJ45® Cable Assemblies	
Part Number	Description
CA77-010M0-8	10 meter cable assembly
CA77-007M0-8	7 meter cable assembly
CA77-005M0-8	5 meter cable assembly
CA77-003M0-8	3 meter cable assembly
CA77-002M0-8	2 meter cable assembly
CA77-001M0-8	1 meter cable assembly

The ARJ45® is Bel Stewart's new family of connectors for Category 7 and Category 7a premise wiring systems deployed in 10Gigabit Ethernet and higher speed data transmission environments. This connector family consists of a cable-mounted plug and a single-port, PCB-mounted jack designed to meet Category 7 performance standards up to 600 MHz as defined by the IEC60603-7-7. These products will also meet proposed Category 7a specifications increasing performance requirements up to 1000 MHz. Additionally, the ARJ45® can be used as a high speed connector replacement for closed loop applications currently using less economical connector types.

Bel Stewart's ARJ45® connector systems provide a competitive advantage in that they are built on the proven reliability of standard RJ45 interface mechanics which have been enhanced to support increased Category 7a data speeds. In addition, the ARJ45® connectors are interface-compatible with the Nexans' GG45 Category 7 connector system. This makes the ARJ45® / GG45 connector system a proven intermatable connector solution for Category 7 and Category 7a that is commercially available today from two independent manufacturing sources.



Bel Stewart Connector GmbH

Industriestrasse 20
61381 Friedrichsdorf
Germany
Tel 49-6172-9552-0

Bel Stewart Connector

11118 Susquehanna Trail South
Glen Rock, PA 17327
Tel 717-235-7512
Fax 717-235-4675



ARJ45[®] Category 7a Connectors



Typical Mechanical Dimensions of ARJ45[®] PCB Jacks

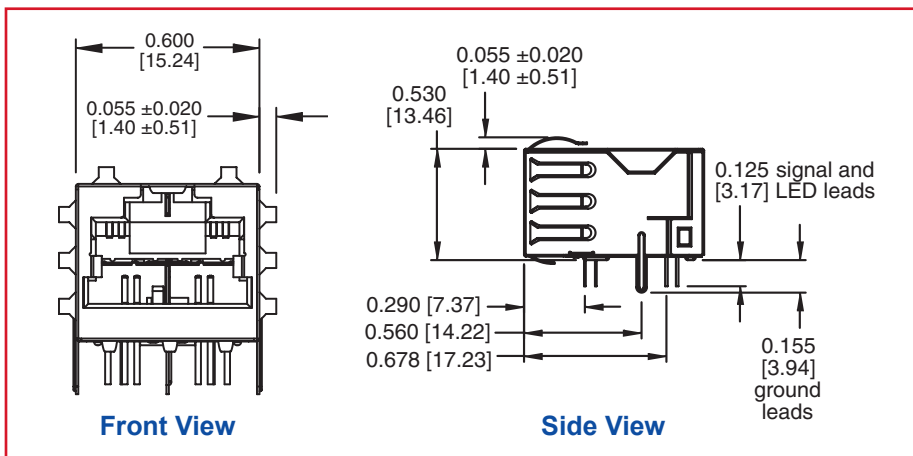

ARJ45[®] Category 7a Application Performance Data

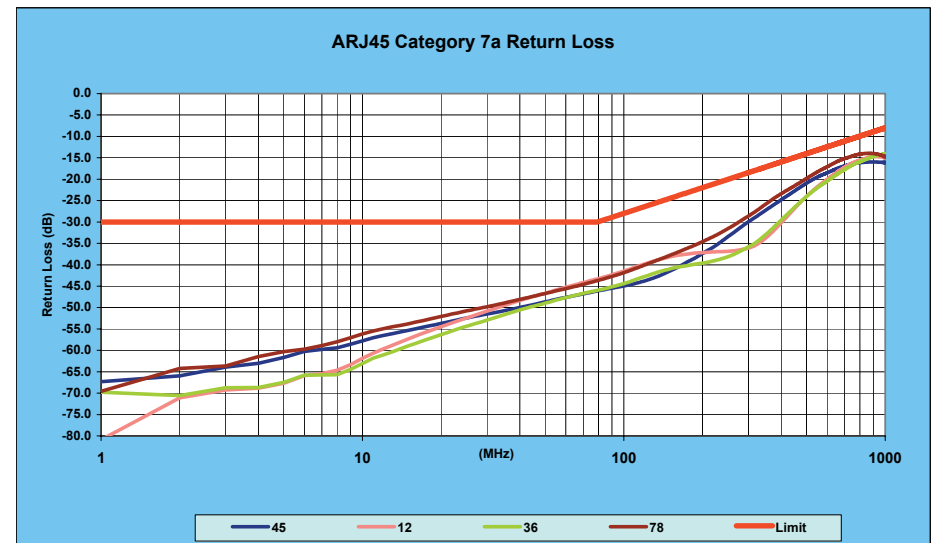

Bel Stewart Connector GmbH
 Industriestrasse 20
 61381 Friedrichsdorf
 Germany
 Tel 49-6172-9552-0

Bel Stewart Connector
 11118 Susquehanna Trail South
 Glen Rock, PA 17327
 Tel 717-235-7512
 Fax 717-235-4675

