

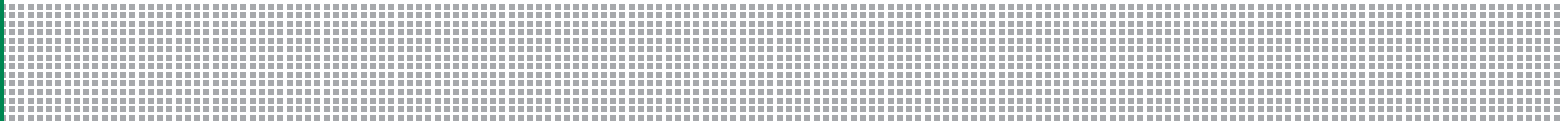

# ESD

## Electrostatic Discharge (ESD) Suppression Design Guide



Expertise Applied | Answers Delivered

# ESD

# Electrostatic Discharge (ESD) Suppression Design Guide

Electrostatic Discharge (ESD) is an electrical transient that poses a serious threat to electronic circuits. The most common cause is friction between two dissimilar materials, causing a buildup of electric charges on their surfaces. Typically, one of the surfaces is the human body, and it is not uncommon for this static charge to reach a potential as high as 15,000 volts. At 6,000 static volts, an ESD event will be painful to a person. Lower voltage discharges may go unnoticed, but can still cause catastrophic damage to electronic components and circuits.

## ABOUT THIS GUIDE

Choosing the most appropriate suppressor technology requires a balance between equipment protection needs and operating requirements, taking into account the anticipated threat level. In addition to the electrical characteristics of suppression devices, the form factor/package style must also be considered. This guide is designed to summarize some of the comprehensive ESD solutions that Littelfuse offers, and help designers narrow to technologies appropriate to their end application:

Table of Contents		Page
ESD Suppression Technologies		2
ESD Damage, Suppression Requirements and Considerations		3
ESD Data Protocol, Application and Product Selection		4
Port Protection Examples		5-10
ESD Suppressor Product Selection Guide		11-17
• Polymer ESD Suppressors		
• Multilayer Varistors (MLVs)		
• TVS Diode Arrays ( SPA <sup>®</sup> Diodes)		
Legal Disclaimers		18

## ESD Suppression Technologies

Protection Technology	Data Rate Span	Peak/Clamp (8kV)	ESD Level	Discrete Options	Array Options	Applications and Circuits	Key Advantages
Multilayer Varistor (MLVs)	< 125Mbps	Good	Good	0402 0603 0805 1206	1206	Keypad/switch, audio, analog video, USB1.1, RS232	Lowest cost; broad discrete offering
TVS Diode Arrays (SPA® Diodes)	0 - > 5Gbps	Excellent	Excellent	0805 (SOD323) 0402 (SOD882, SOD-883, SOD723) 0201 (Flipchip, $\mu$ DFN-2) 01005 (Flipchip), 1103-DFN, 0802-DFN	SOIC-8 SOT143 SOT23 SC70 SOT553 SOT563 SOT953 MSOP 8 MSOP 10 $\mu$ DFN TDFN	Keypad/switch, USB1.1, USB2.0, USB3.0, USB3.1 Type C, audio, analog video, FireWire 1394, HDMI, Ethernet, MMC interface, LCD module.. RS232, RS485, CAN, LIN	Lowest peak and clamp voltages
PULSE-GUARD® ESD Suppressors	100Mbps -> 5Gbps	Good	Good	0201 0402 0603	SOT23	USB2.0, FireWire 1394, HDMI/USB3.0, RF antenna	Lowest capacitance

### When to Choose PULSE-GUARD® ESD Suppressors

- The application tolerates very little added capacitance (high speed data lines or RF circuits)
- ESD is the only transient threat
- Protection is required on data, signal, and control lines (not power supply lines)

### When to Choose TVS Diode Arrays (SPA® Diodes)

- The device being protected requires the lowest possible clamp voltage, low capacitance (0.1pF-400pF) and low leakage (0.01 $\mu$ A – 10 $\mu$ A)
- Board space is at a premium and space-savings multi-line protection is needed
- Transients other than ESD, such as EFT or lightning, must also be considered

### When to Choose Multilayer Varistors (MLVs)

- Surge currents or energy beyond ESD is expected in the application (EFT, lightning)
- Added capacitance is desirable for EMI filtering (3pF – 6000pF)
- Power supply line or low/medium speed data and signal lines are to be protected
- The operating voltage is above silicon or PULSE-GUARD® ESD suppressor ratings

## ESD Damage, Suppression Requirements and Considerations

### ESD Damage

ESD is characterized by fast rise times and high peak voltages and currents up to 30 amps (per IEC 61000-4-2, level 4), which can melt silicon and conductor traces. However, ESD effects can be more subtle. The three types of damage are:

#### 1. Soft Failures

Electrical currents due to ESD can change the state of internal logic, causing a system to latch up or behave unpredictably, or cause corruption of a data stream. While this is temporary, it may slow down communications, or require a system reboot in the case of lockup.

#### 2. Latent Defects

A component or circuit may be damaged by ESD and its function degraded though the system will continue to work. However, this type of defect often progresses to a premature failure.

#### 3. Catastrophic Failures

Of course, ESD can damage a component to the point where it does not function as intended, or doesn't work at all.

### ESD Suppression Requirements

The likelihood of electronic circuit damage is increasing as integrated circuit (IC) dimensions are shrinking to nanometer sizes. Most ICs operate at low voltages and have structures and conductive paths that cannot survive the high currents and voltages associated with ESD transients.

Another significant trend is the migration to higher frequency communication devices to transmit more information in less time. This means that ESD solutions must not compromise stringent signal integrity requirements at the higher data rates. Therefore, ESD suppressors must have low internal capacitance so that data communication signals are not distorted.

IC designers add a limited amount of ESD suppression to their chips to help avoid damage during manufacturing and assembly processes. However, the level of protection that is added may not be sufficient to protect ICs and other semiconductor devices from ESD during actual usage. Many electronic products, especially portable ones, are used in uncontrolled environments. Portable devices can experience a charge buildup as they are carried by users on their person or in a purse. This energy can then be discharged to another device as the two are connected, usually when a user touches I/O pins on a cable connector. Therefore, end product designers should consider adding ESD suppressors to their circuits.

Figure 1. ESD Test Waveform

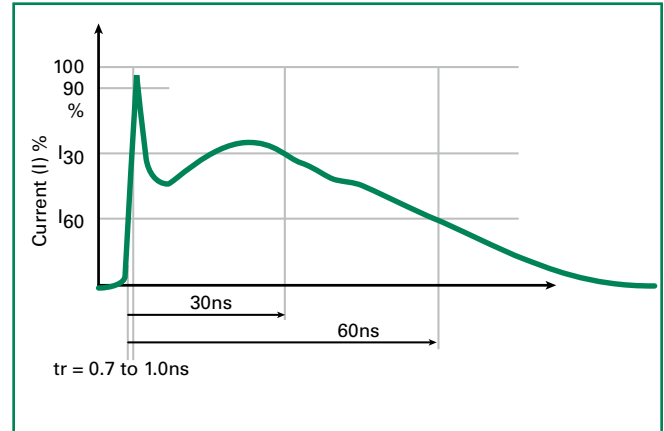

### ESD Suppression and Circuit Design Considerations

Proper use of ESD circuit protection helps prevent these failures. Still, selection of a suppression device must recognize that ESD has very short rise and fall times—less than one nanosecond (1ns) in most cases. The International Electrotechnical Commission (IEC) has developed a specification (IEC 61000-4-2) for ESD testing that helps determine if products are susceptible to ESD events.

Littelfuse device engineers use specifications like these to design ESD suppressors with the speed, clamping voltage, and residual current levels that will protect today's sensitive semiconductors and electronic circuitry. Many of these designs have the low internal capacitance needed for high bandwidth communications.

When selecting ESD suppressors, circuit designers need to consider potential coupling paths that would allow ESD to enter their equipment and circuits. These weak points identify areas that should be considered for ESD suppressor installation. Ultimately, designers need to select ESD suppressors with characteristics appropriate for their type of equipment, the component sensitivity, and the environment where it will be used.

A robust web-based tool to help circuit designers identify the optimal electronic fuses for their products.



Littelfuse iDesign™ Online Fuse Design and Selection Tool

## Data Protocol, Application and Product Selection

The chart below shows the relationship between Data Rates (Protocol), Applications, and Littelfuse ESD suppression products.

The top of the chart shows the standard data protocols, associated data rates, and example end applications that may use the protocols, while the body of the chart shows the applicable Littelfuse ESD suppressors for the various data rates, protocols and applications.

The characteristic of concern here is capacitance. High capacitance suppression devices will tend to add signal distortion as signal frequencies increase; low capacitance devices will maintain signal integrity at high data rates.

Note that an application may use several different data protocols and could use as many different ESD suppressor products. For example, a laptop computer could have RS232, USB 2.0, video, and PS2 mouse ports, as well as others.

The RS232 and mouse ports use relatively slow data rates and could use any Littelfuse suppressor (although higher capacitance multi-layer or silicon parts are preferred for EMI filtering capabilities). The appropriate protector for the video port would depend on the data rate, and since the USB 2.0 port requires an extremely low capacitance suppression device, PULSE-GUARD® ESD Suppressor or TVS Diode Array (SPA® Diodes) devices should be considered.

Littelfuse MLV device can be connected near the I/O port to clamp the ESD or surge event with SMD package and wide capacitance range to as low as 3pF, MLV is widely used from Audio, control, as well as dataline communication such as USB2.0

If you require further assistance in selecting the appropriate Littelfuse ESD suppressor for your specific circuit, please contact your local Littelfuse products representative.

## PRODUCT SERIES AND APPLICABLE DATA RATES AND PROTOCOLS

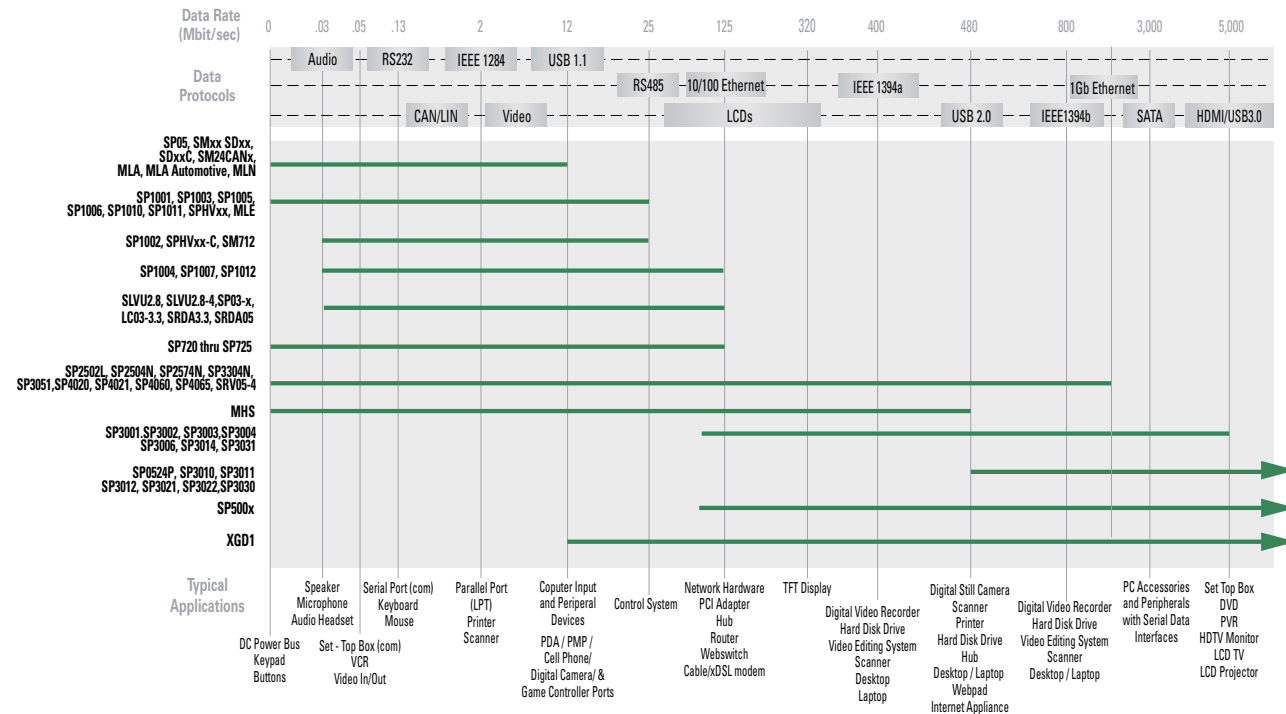

The information above is intended to help circuit designers determine which Littelfuse ESD suppressors are applicable for given data protocols and data rates. Other key characteristics such as clamping voltage, leakage current, number of lines of protection and ESD capabilities need to be considered, especially where there are overlaps in the recommended Littelfuse ESD suppressor line (ex. IEEE 1284 and Ethernet). This information is detailed on the following pages.

At the upper data rate bounds of the products included above, the capacitances of the suppression device and the circuit board need to be taken into account in order to maintain the signal integrity of the overall system.

## Port Protection Examples



### BROADBAND NETWORK PORT PROTECTION

The following are examples of the implementation of ESD and lightning suppression for Ethernet ports (RJ-45 connectors). Note that the diagrams shown below represent 10Mbps and 100Mbps applications -- For 1Gbps applications, the circuit protection should be double of what is shown. For additional design examples, guidance and application assistance, please contact Littelfuse.

### Inter-Building - Robust Lightning Protection

The diagram show below is typical for outdoor network line and equipment applications. The SIDACTor® and TVS Diode Array combination is rated up to 500A, per the GR-1089 standard.

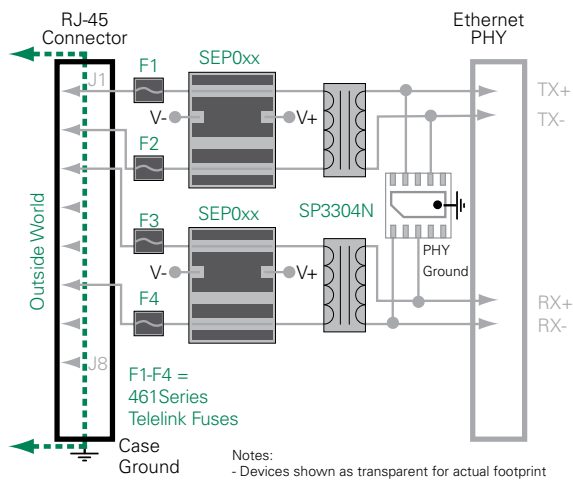

### Intra-Building - Robust Lightning Protection

The diagram show below is typical for indoor network line and equipment applications. The TVS Diode Array device combination is rated up to 100A, per the GR-1089 standard.

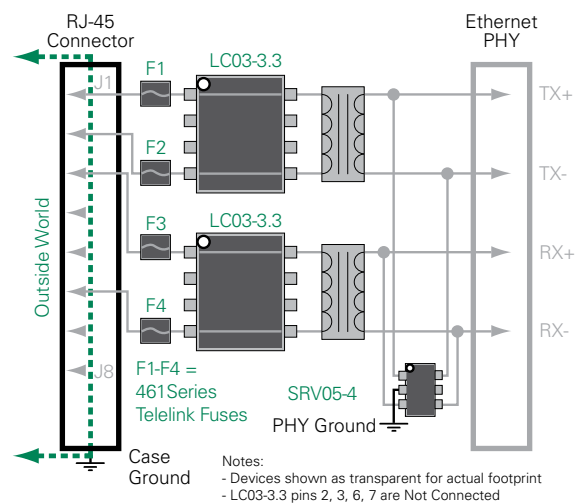

### Basic Lightning Protection

The diagram shown below is typical for basic lightning (differential only) of indoor/outdoor network line and equipment applications (Example: office environment equipment).

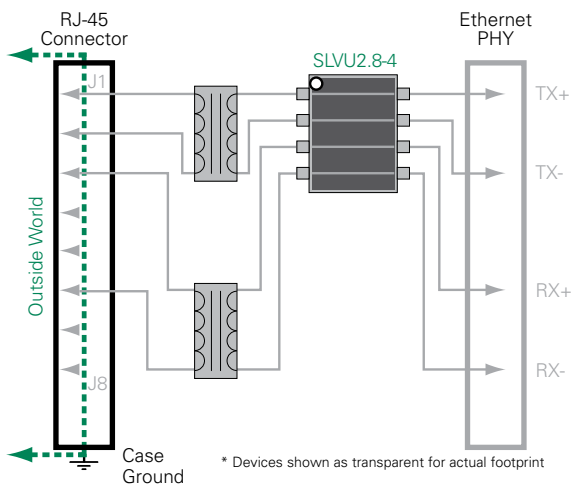

### Basic ESD Protection

The diagram shown below is typical for basic ESD protection of indoor network line and equipment applications (Examples: home office / consumer electronics peripheral devices).

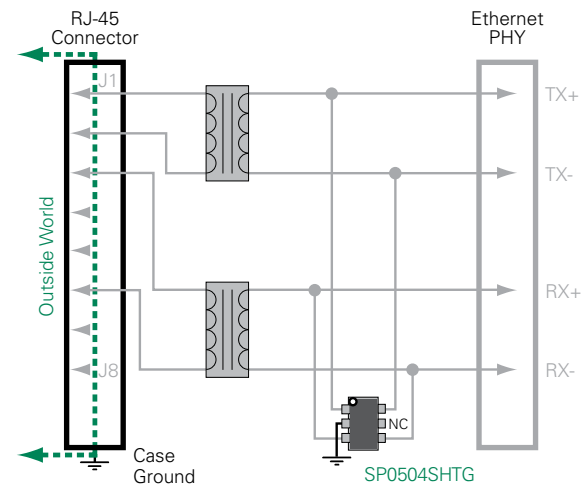

## Port Protection Examples (continued)



### PERIPHERAL / STORAGE DATA PORT PROTECTION

The following are examples of ESD suppression for high speed data ports such as USB and eSATA. For additional design examples, guidance and application assistance, please contact Littelfuse.

#### USB 1.1 port ESD protection

Data speeds up to 12 Mbps

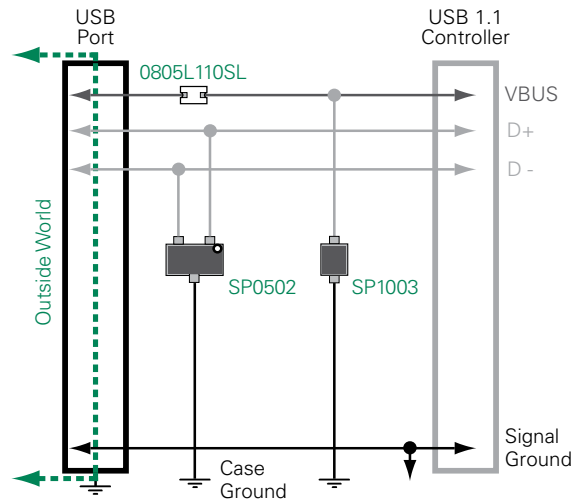
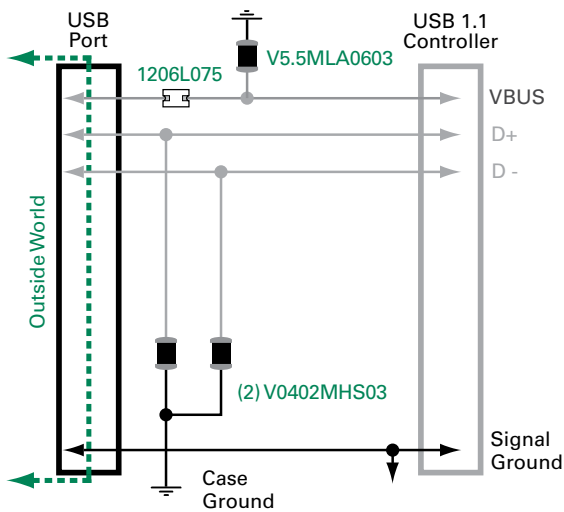

Note:  
The SP0503BAHTG could be used if it's preferred to have all 3 channels in 1 package.

#### USB 2.0 port ESD protection

Data speeds up to 480 Mbps

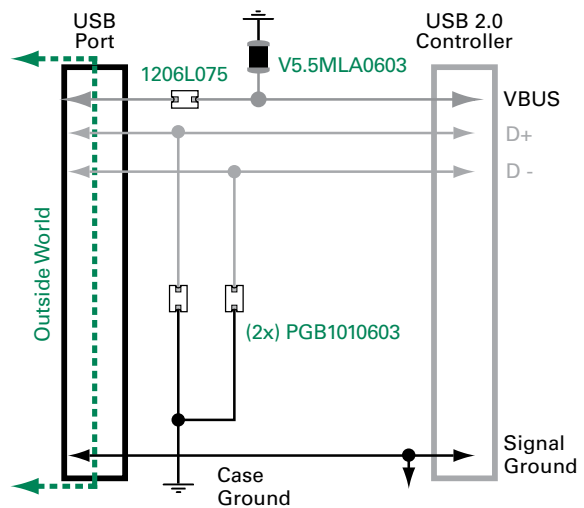
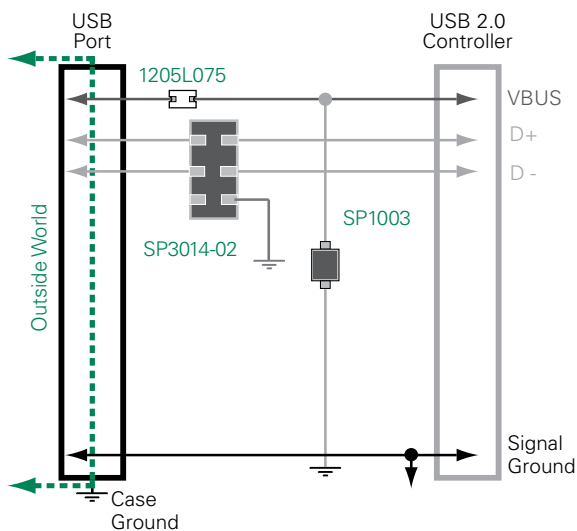

## Port Protection Examples (continued)

### USB 3.0 port ESD protection

Data speeds up to 5 Gbps

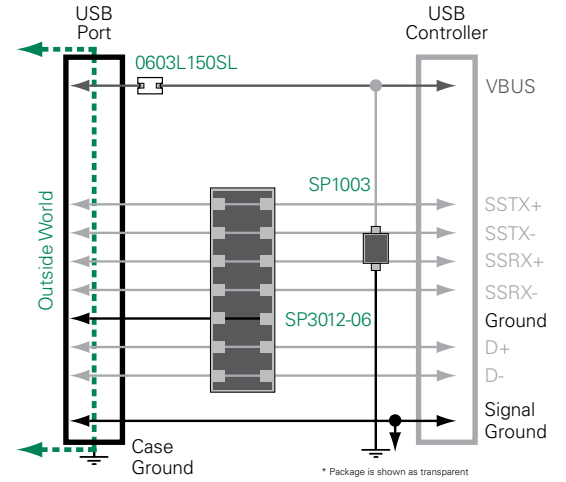
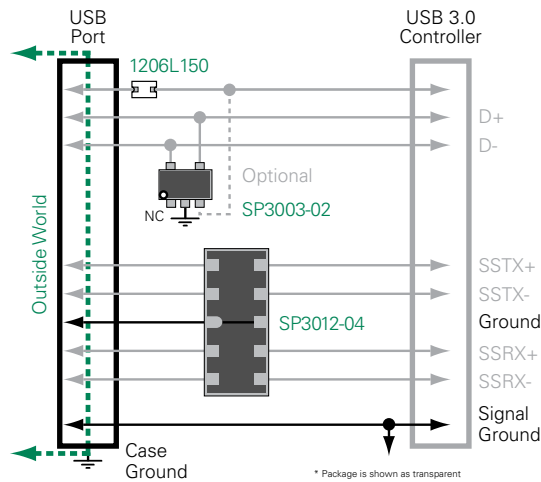

### USB 3.1 type C ESD Protection

Application Schematic:

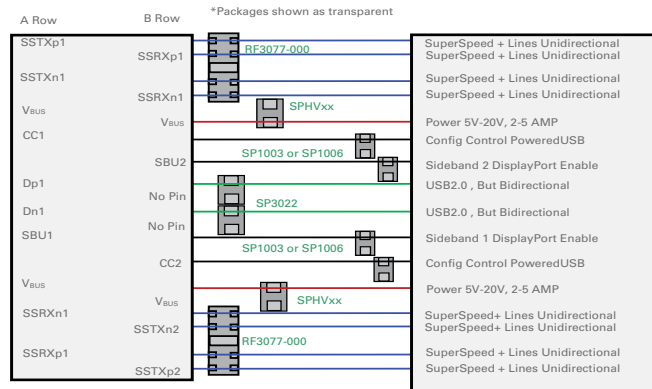

### eSATA port protection

Data speeds up to 3 Gbps

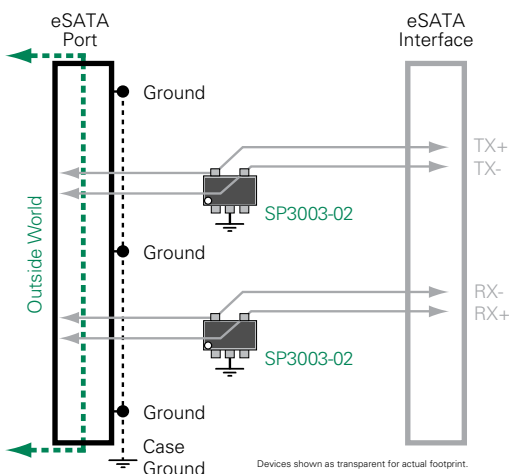

### 1394a/b Firewire port ESD protection

Data speeds up to 800 Mbps

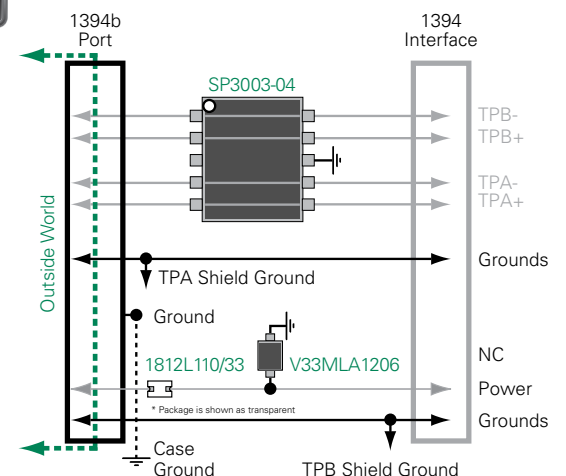

## Port Protection Examples (continued)



### ENTERTAINMENT ELECTRONICS PORT PROTECTION

The following are examples of ESD suppression for ports common to entertainment electronics. For additional design examples, guidance and application assistance, please contact Littelfuse.

#### Analog audio (Speaker/Microphone) port ESD protection

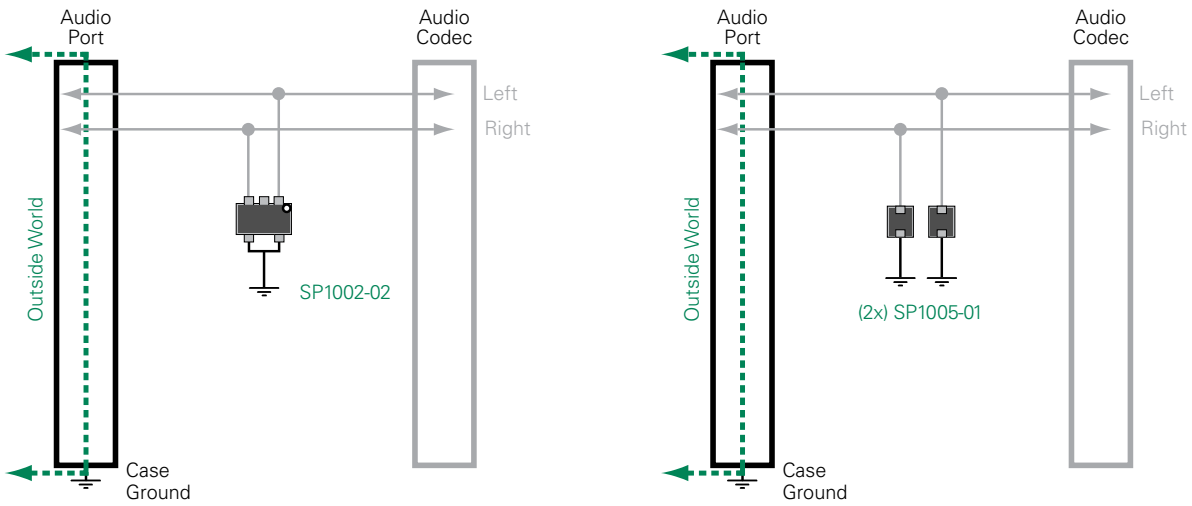

#### Analog video port ESD protection

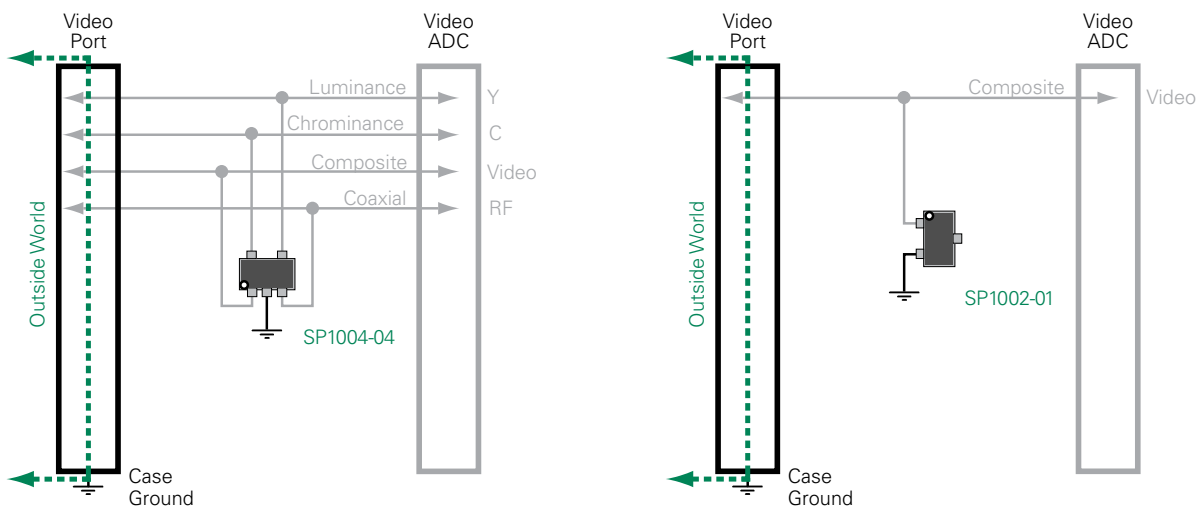

## Port Protection Examples (continued)



### High Definition Multimedia Interface (HDMI) port ESD protection

Data speeds up to 3.4 Gbps per pair

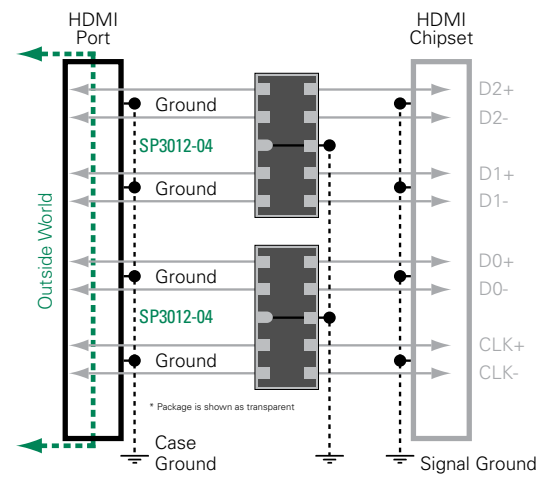
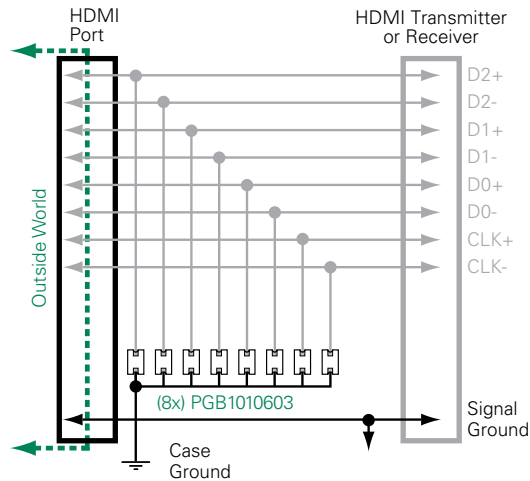

### Keypad / push button ESD protection

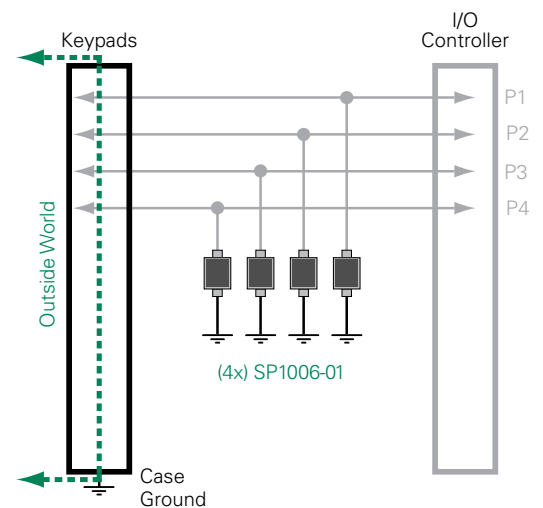
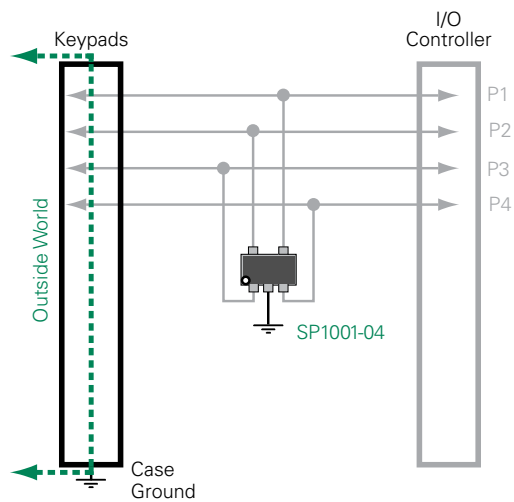

## Port Protection Examples (continued)



### AUTOMOTIVE ELECTRONICS PORT PROTECTION

The following are examples of ESD suppression for automotive electronics. For additional design examples, guidance and application assistance, please contact Littelfuse.

#### Automotive AEC-Q101 qualified ESD protection

##### LIN BUS protection

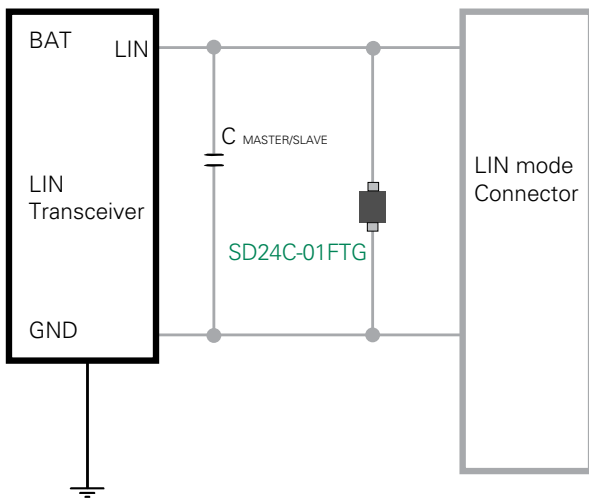

##### CAN BUS protection

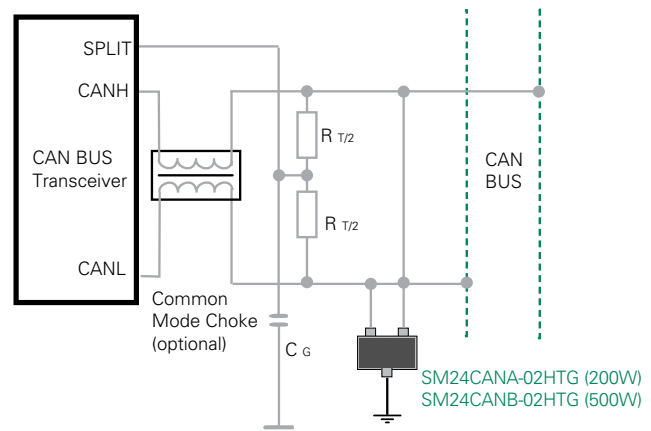

### RF Antenna protection

The following are examples of ESD suppression for RF antenna. For additional design examples, guidance and application assistance, please contact Littelfuse.

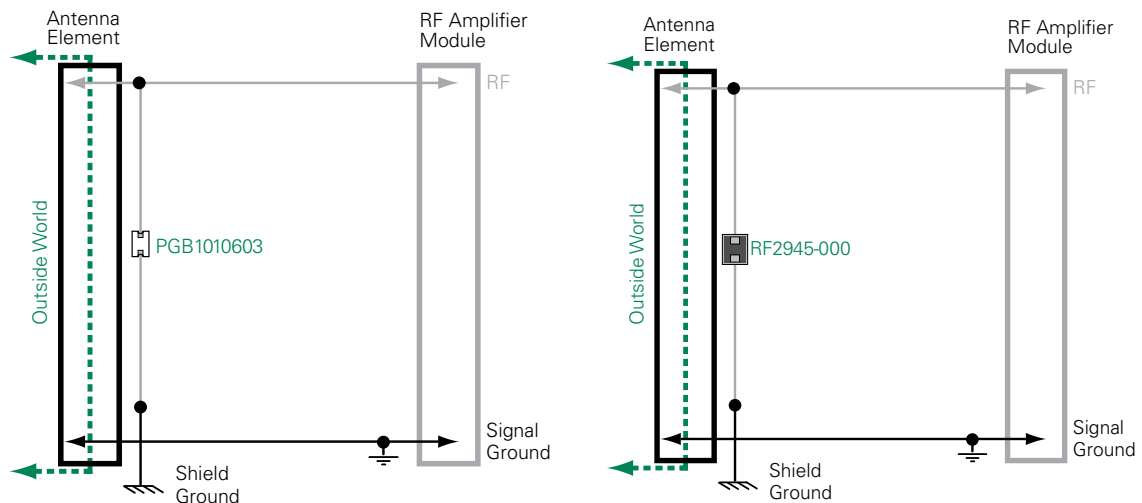

## ESD Suppressor Product Selection Guide

Polymer ESD Suppressors

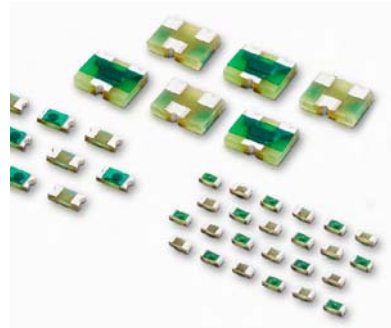

Multilayer Varistors (MLVs)



	Polymer ESD Suppressor Pulse-Guard® ESD Suppressors	Polymer ESD Suppressor Xtreme-Guard® ESD Suppressors	Multilayer Varistors (MLVs)				
	Surface Mount	Surface Mount	Surface Mount	Surface Mount	Surface Mount	Surface Mount	Surface Mount
Mounting Options	Surface Mount	Surface Mount	Surface Mount	Surface Mount	Surface Mount	Surface Mount	Surface Mount
Series Name	PGB1, PGB2	XGD1	MLA	MLA Automotive	MLE	MHS	MLN
Technology Type	Voltage Variable Material	Voltage Variable Material	MLV ZnO	MLV	MLV ZnO	MLV ZnO	MLV ZnO
Working Voltage	0–24VDC	0 - 32VDC	0–120VDC range by type	ZnO	0–18VDC	0–42VDC	0–18VDC
Array Package (No. of Lines)	SOT23 (2)	NA	NA	0 - 42VDC	NA	NA	1206 (4)
Single Line Package	0201, 0402, 0603	0402, 0603	0402–1210	NA	0402–1206	0402, 0603	NA
Typical Device Capacitance	0.04-0.12pF	0.04 - 0.09 pF	40–6000pF	0603 - 1210	40–1700pF	3–22pF	45-430pF
Leakage Current	<1nA typ	< 1 nA Typ	<25µA typ	90 - 7500 pF	<25µA max	<25µA typ	<25µA max
Rated Immunity to IEC 61000-4-2 level 4	Yes	Yes	Yes	< 25 uATyp	Yes	Yes	Yes
Also Rated for EFT or Lightning	No	No	Yes	Yes	Yes	Yes	Yes
Bidirectional (transients of either polarity)	Yes	Yes	Yes	Yes	Yes	Yes	Yes
Performs Low Pass Filtering	No	No	Yes	Yes	Yes	Yes	Yes
Lead-Free	Yes	Yes	No	Yes	No	No	No
RoHS Compliant	Yes	Yes	Yes	No	Yes	Yes	Yes
HF	Yes	Yes	Yes	Yes	Yes	Yes	Yes
AEC-Q Qualified (Automotive Grade )	No	No	No	Yes	No	No	No

Please refer to this table and the next few pages in selecting the ESD suppressors that may best serve the circuit requirements. Detailed data sheets can be downloaded from our web site [www.littelfuse.com](http://www.littelfuse.com)

Terms:

EFT: Electrical Fast Transient

TVS: Transient Voltage Suppressor

## ESD Suppressor Product Selection Guide (continued)

### TVS Diode Arrays (SPA® Diodes)

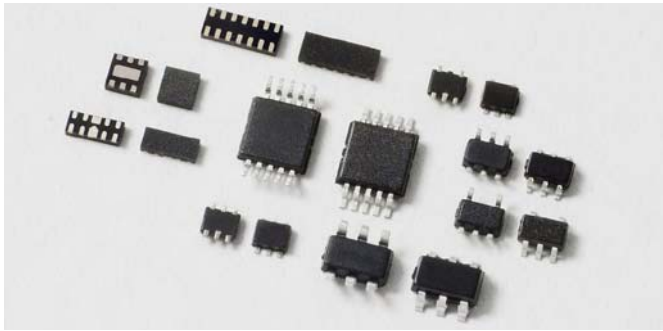

Please refer to this table and the next few pages in selecting the ESD suppressors that may best serve the circuit requirements.

Detailed data sheets can be downloaded from our web site [www.littelfuse.com](http://www.littelfuse.com)

Terms:

EFT: Electrical Fast Transient

TVS: Transient Voltage Suppressor

	TVS Diode Arrays (SPA® Diodes)									
Mounting Options	Surface Mount & Thru-Hole	Surface Mount	Surface Mount	Surface Mount	Surface Mount	Surface Mount	Surface Mount	Surface Mount	Surface Mount	Surface Mount
Series Name	SP72x	SP03-xx(LC03)	SP05x	SP10xx	SP30xx	SLVU2.8x	SP500x	SMxx	SPHVxx(-C)	SESD
Technology Type	Silicon Controlled Rectifier / Diode	Lightning Surge Protection Diode Arrays	General Purpose ESD Protection Diode Arrays	General Purpose ESD Protection Diode Arrays and Discretes	Low Capacitance Diode Arrays	Lightning Surge Protection Diode Arrays	Low Capacitance Common Mode Filters with ESD Protection	General Purpose ESD Protection Diode Arrays	Discrete General Purpose ESD Protection	Enhanced ESD Protection
Working Voltage	0-30VDC	0-6VDC	0-5.5VDC	0-6VDC	0-6VDC	0-2.8V	5VDC	5-36VDC	12-36VDC	7V
Array Package (No. of Lines)	PDIP, SOIC (6, 14) SOT23 (4)	SOIC (2)	SOT23 (2, 4, 5), SOT143 (3), MSOP-8 (6), SC70 (2, 4, 5)	SC70 (1, 2, 4, 5), SOT5x3 (2, 4, 5), SOT953 (4), µDFN (4)	SC70 (2, 4), SOT5x3 (2, 4), SOT23 (4), MSOP10 (4), µDFN (2, 4, 6)	SOIC (4)	TDFN (10/16)	SOT23 (2)	NA	SOD883 (2) 1004 DFN(4) 0802 DFN(4) 1103DFN(6)
Single Line Package	NA	NA	NA	0402 (SOD723 and SOD882) 0201 (Flip Chip)	0402 (SOD882) 0201 (Flipchip)	SOT23	NA	NA	0402 (SOD882)	0201 DFN SOD882
Typical Device Capacitance	3-5pF	4.5-8pF	30pF	5-30pF	0.30-2.4pF	2.0pF	0.8pF	11-400pF	13-60pF	0.1-0.3pF
Leakage Current	<0.02µA max	<0.5µA max	<10µA max	<0.5µA max	<1.5µA max	<1µA max	<1µA max	<20µA max	<1µA max	<0.05µA max
Rated Immunity to IEC 61000-4-2 level 4	Yes	Yes	Yes	Yes	Yes	Yes	Yes	Yes	Yes	Yes
Also Rated for EFT or Lightning	Yes	Yes	Yes	Yes	Yes	Yes	No	Yes	Yes	Yes
Bidirectional (transients of either polarity)	Yes	Yes	Yes	Yes	Yes	Yes	Yes	Yes	Yes	Yes
Performs Low Pass Filtering	No	No	No	SP1005 only	No	No	Yes	Yes	Yes	Yes
Lead-Free	Yes	Yes	Yes	Yes	Yes	Yes	Yes	Yes	Yes	Yes
RoHS Compliant	Yes	Yes	Yes	Yes	Yes	Yes	Yes	Yes	Yes	Yes
Green	Yes (except PDIP)	Yes	Yes	Yes	Yes	Yes	Yes	Yes	Yes	No
AEC-Q Qualified (Automotive Grade)	No	No	No	AEC-Q101	AEC-Q101	No	AEC-Q101	AEC-Q101	AEC-Q101	AEC-Q101

## ESD Suppressor Product Selection Guide (continued)

### TVS DIODE ARRAY – SPA® DIODES

TVS Diode Arrays offer a high level of protection (up to 30kV per IEC 61000-4-2) with very low capacitance, leakage current and clamping voltage. For more robust applications, Lightning Surge devices are available for EFT and Lightning transient threats per IEC 61000-4-4/5. threats per IEC 61000-4-4/5.

Series Name	ESD Level (Contact)	I/O Capacitance	$V_{RWM}$	Lighting (tp=8/20µs)	Number of Channels	Package	Orderable Part Number
<b>General Purpose ESD Protection (TVS Discretes and Array)</b>							
SP05	±30kV	30pF	5.5V	N/A	2	SOT23-3	SP0502BAHTG
						SC70-3	SP0502BAJTG
					3	SOT143	SP0503BAHTG
						4	SOT23-5
					SC70-5		SP0504BAJTG
					5	SOT23-6	SP0505BAHTG
SC70-6	SP0505BAJTG						
SP1001	±15kV	8pF	5.5V	2A	2	SC70-3	SP1001-02JTG
						SOT553	SP1001-02XTG
					4	SC70-5	SP1001-04JTG
						SOT553	SP1001-04XTG
					5	SC70-6	SP1001-05JTG
						SOT563	SP1001-05XTG
SOT963	SP1001-05VTG						
SP1002	±8kV	5pF	6V	2A	1	SC70-3	SP1002-01JTG
					2	SC70-5	SP1002-02JTG
SP1003	±30kV	30pF	5V	7A	1	SOD723	SP1003-01DTG
						SOD882 (0402)	SP1003-01ETG
SP1004	±8kV	5pF	6V	2A	4	SOT953	SP1004-04VTG
SP1005	±30kV	23pF	6V	10A	1	Flipchip (0201)	SP1005-01WTG
						SOD882 (0402)	SP1005-01ETG
SP1006	±30kV	15pF	6V	5A	1	µDFN-2 (0201)	SP1006-01UTG
						Flipchip (0201)	SP1007-01WTG
SP1007	±8kV	5pF	6V	2A	1	SOD882 (0402)	SP1007-01ETG
						Flipchip (0201)	SP1008-01WTG
SP1008	±15kV	8pF	6V	3A	1	Flipchip (0201)	SP1008-01WTG
SP1011	±15kV	7pF	6V	2A	4	µDFN-6	SP1011-04UTG
SP1012	±15kV	6.5pF	5V	3A	5	Flipchip 0.94x0.61mm	SP1012-05WTG
SP1013	±30kV	30pF	5V	8A	1	Flipchip 0.54x0.29mm	SP1013-01WTG
SP1014	±12kV	6pF	5V	2A	1	Flipchip 0.54x0.29mm	SP1014-01WTG
SP1015	±20kV	5pF	5V	2A	4	Flipchip 0.93x0.53mm	SP1015-04WTG
SP1020	±30kV	20pF	6V	5A	1	Flipchip 01005	SP1020-01WTG
SP1021	±12kV	6pF	6V	2A	1	Flipchip 01005	SP1021-01WTG
SDxx	±30kV	350pF	5V	30A	1	SOD323 (0805)	SD05-01FTG
		150pF	12V	17A			SD12-01FTG
		100pF	15V	12A			SD15-01FTG
		65pF	24V	7A			SD24-01FTG
		50pF	36V	5A			SD36-01FTG
SDxx-C	±30kV	200pF	5V	30A	1	SOD323 (0805)	SD05C-01FTG
		100pF	12V	17A			SD12C-01FTG
		75pF	15V	12A			SD15C-01FTG
		50pF	24V	7A			SD24C-01FTG
		30pF	36V	5A			SD36C-01FTG
SM24CANA	±24kV	11pF	24V	3A	2	SOT23-3	SM 24CANA-02HTG
SM24CANB	±30kV	30pF	24V	10A	2	SOT23-3	SM 24CANB-02HTG
SM712	±30kV	75pF	+12V/-7V	17A	2	SOT23-3	SM712-02HTG

## ESD Suppressor Product Selection Guide (continued)

Series Name	ESD Level (Contact)	I/O Capacitance	V <sub>RWM</sub>	Lighting (tp=8/20μs)	Number of Channels	Package	Orderable Part Number
<b>General Purpose ESD Protection (TVS Discretes and Array) Cont.</b>							
SPHVxx- 01ETG	±30kV	30pF		8A	1	SOD882 (0402)	SPHV12-01ETG
	±30kV	24pF		5A			SPHV15-01ETG
	±24kV	17pF		3A			SPHV24-01ETG
	±15kV	13pF		2A			SPHV36-01ETG
SPHVxx- 01ETG-C	±30kV	60pF		8A	1	SOD882 (0402)	SPHV12-01ETG-C
	±30kV	46pF		5A			SPHV15-01ETG-C
	±24kV	32pF		3A			SPHV24-01ETG-C
	±15kV	25pF		2A			SPHV36-01ETG-C
SPHVxx- 01KTG-C	±30kV	60pF		8A	1	*SOD882 (0402)	SPHV12-01KTG-C
	±30kV	46pF		5A			SPHV15-01KTG-C
	±24kV	32pF		3A			SPHV24-01KTG-C
	±15kV	25pF		2A			SPHV36-01KTG-C
SPxx- 01WTG-C- HV	±30kV	26pF		8A	1	Flipchip (0201)	SP12-01WTG-C-HV
	±30kV	21pF		5A			SP15-01WTG-C-HV
	±18kV	13pF		3A			SP24-01WTG-C-HV
	±10kV	10pF		1.5A			SP36-01WTG-C-HV
SMxx	±30kV	400pF	5V	24A	2	SOT23-3	SM05-02HTG
		150pF	12V	17A			SM12-02HTG
		100pF	15V	12A			SM15-02HTG
		65pF	24V	7A			SM24-02HTG
		50pF	36V	5A			SM36-02HTG
<b>Low Capacitance ESD Protection</b>							
SP1255P	±12kV	0.5pF	4V	4A	3	uDFN-6	SP1255PUTG
SP3001	±8kV	0.65pF	6V	2.5A	4	SC70-6	SP3001-04JTG
SP3002	±12kV	0.85pF	6V	4.5A	4	SC70-6	SP3002-04JTG
						uDFN-6	SP3002-04UTG
SP0504S	±12kV	0.85pF	6V	4.5A	4	SOT23-6	SP0504SHTG
SP3003	±8kV	0.65pF	6V	2.5A	2	SC70-5	SP3003-02JTG
						SOT553	SP3003-02XTG
					4	uDFN-6	SP3003-02UTG
						SC70-6	SP3003-04JTG
						SOT563	SP3003-04XTG
8	MSOP-10	SP3003-04ATG					
MSOP-10	SP3003-08ATG						
SP3004	±12kV	0.85pF	6V	4A	4	SOT563	SP3004-04XTG
SP3010	±8kV	0.45pF	6V	3A	4	uDFN-10	SP3010-04UTG
SP3011	±8kV	0.4pF	6V	3A	6	uDFN-14	SP3011-06UTG
SP3012	±12kV	0.5pF	5V	4A	3	uDFN-6	SP3012-03UTG
					4	SOT23-6	SP3012-04HTG
					4	uDFN-10	SP3012-04UTG
					6	uDFN-14	SP3012-06UTG
SP3014	±15kV	1.0pF	5V	8A	2	uDFN-6L	SP3014-02UTG
SP0524P	±12kV	0.5pF	5V	4A	4	uDFN-10	SP0524PUTG
SP3021	±8kV	0.5pF	5V	2A	1	SOD882 (0402)	SP3021-01ETG

## ESD Suppressor Product Selection Guide (continued)

Series Name	ESD Level (Contact)	I/O Capacitance	V <sub>RWM</sub>	Lighting (tp=8/20μs)	Number of Channels	Package	Orderable Part Number
<b>Low Capacitance ESD Protection (Cont.)</b>							
SP3022	±20kV	0.35pF	5.3V	3A	1	Flipchip 0201 SOD882 (0402)	SP3022-01WTG SP3022-01ETG
SP3030	±20kV	0.5pF	5V	3A	1	SOD882 (0402)	SP3030-01ETG
SP3031	±10kV	0.8pF	5V	5A	1	SOD882 (0402)	SP3031-01ETG
SESD0201X1UN- 0030-088	±22kV	0.30 pF	7V	2.5A	1	0201 DFN	RF3917-000
SESD0201X1BN- 0015-096	±22kV	0.15 pF	7V	2.5A	1	0201 DFN	RF3918-000
SESD0402X1UN- 0030-088	±22kV	0.30 pF	7V	2.5A	1	SOD882 (0402)	RF3920-000
SESD0402X1BN- 0015-096	±22kV	0.15 pF	7V	2.5A	1	SOD882 (0402)	RF3922-000
SESD0402Q2UG- 0030-088	±22kV	0.30 pF	7V	2.2A	2	0402 DFN (SOD883)	RF3925-000
SESD1004Q4UG- 0030-088	±22kV	0.30 pF	7V	2.2A	4	1004 DFN	RF3923-000
SESD0402Q2UG- 0020-090	±20kV	0.20pF	7V	2.0A	2	0402 DFN (SOD883)	RF2946-000
SESD0802Q4UG- 0020-090	±20kV	0.20pF	7V	2.0A	4	0802 DFN	RF3076-000
SESD1004Q4UG- 0020-090	±20kV	0.20pF	7V	2.0A	4	1004 DFN	RF3077-000
SESD1103Q6UG- 0020-090	±20kV	0.20pF	7V	2.0A	6	1103 DFN	RF3078-000
SESD0201X1UN- 0020-090	±20kV	0.20pF	7V	2.0A	1	0201 DFN	RF2192-000
SESD0201X1BN- 0010-098	±20kV	0.10pF	7V	2.0A	1	0201 DFN	RF2193-000
SESD0402X1UN- 0020-090	±20kV	0.20pF	7V	2.0A	1	SOD882 (0402)	RF2943-000
SESD0402X1BN- 0010-098	±20kV	0.10pF	7V	2.0A	1	SOD882 (0402)	RF2945-000
Series Name	ESD Level (Contact)	I/O to I/O Capacitance	V <sub>RWM</sub>	Lighting (tp=8/20μs)	Number of Channels	Package	Orderable Part Number
<b>Ethernet and Lightning Surge Protection</b>							
SRV05-4	±20kV	1.2pF	6V	10A	4	SOT23-6	SRV05-4HTG
SP2504N	±30kV	2.0pF	2.5V	20A	4	uDFN-10	SP2504NUTG
SP3304N	±30kV	2.0pF	3.3V	20A	4	uDFN-10	SP3304NUTG
SP4044	±30kV	1.5pF	2.8V	24A	4	MSOP-10	SP4044-04ATG
SP4045	±30kV	1.5pF	3.3V	24A	4	MSOP-10	SP4045-04ATG
SP4060	±30kV	2.2pF	2.5V	20A	8	MSOP-10	SP4060-08ATG
SP4065	±30kV	2.2pF	3.3V	20A	8	MSOP-10	SP4065-08ATG
SP3051	±30kV	2.0pF	6V	20A	4	SOT23-6	SP3051-04HTG
SP3312T	±30kV	1.3pF	3.3V	15A	4	uDFN-8	SP3312TUTG
SR05	±30kV	3.0pF	5V	25A	2	SOT143	SR05-02CTG
SP4020	±30kV	2.5pF	3.3V	30A	1 (uni) 1 (bidir)	SOD323 (0805)	SP4020-01FTG SP4020-01FTG-C
SP4021	±30kV	2.5pF	5V	25A	1 (uni) 1 (bidir)	SOD323 (0805)	SP4021-01FTG SP4021-01FTG-C
SP4022	±30kV	1.3pF	12V	15A	1 (uni) 1 (bidir)	SOD323 (0805)	SP4022-01FTG SP4022-01FTG-C
SP4023	±30kV	1.3pF	15V	12A	1 (uni) 1 (bidir)	SOD323 (0805)	SP4023-01FTG SP4023-01FTG-C
SP4024	±30kV	1.3pF	24V	7A	1 (uni) 1 (bidir)	SOD323 (0805)	SP4024-01FTG SP4024-01FTG-C
SRDA05	±30kV	4.0pF	5V	30A	4	SOIC-8	SRDA05-4BTG
SRDA3.3	±30kV	4.0pF	3.3V	35A	4	SOIC-8	SRDA3.3-4BTG
SR70	±30kV	2.0pF	70V	40A	2	SOT143	SR70-02CTG
SLVU2.8-4	±30kV	2.0pF	2.8V	40A	4	SOIC-8	SLVU2.8-4BTG
SLVU2.8-8	±30kV	2.6pF	2.8V	30A	8	SOIC-8	SLVU2.8-8BTG
SP2502L	±30kV	2.5pF	3.3V	75A	2	SOIC-8	SP2502LBTG
SP2574N	±30kV	3.8pF	2.5V	40A	4	uDFN-10	SP2574NUTG
SP03-3.3	±30kV	8pF	3.3V	150A	2	SOIC-8	SP03-3.3BTG
LC03-3.3	±30kV	4.5pF	3.3V	150A	2	SOIC-8	LC03-3.3BTG
SP03-6	±30kV	8pF	6V	150A	2	SOIC-8	SP03-6BTG

## ESD Suppressor Product Selection Guide (continued)

### MULTILAYER VARISTORS (MLVS)

MLVs provide board level protection against ESD, EFT, and other transients that occur on power supply, data and control lines. Single line devices are available in popular industry standard formats, and for more efficient board space usage, four-line devices are also available. Some MLVs also offer low band-pass filtering characteristics that filter high frequency noise from the circuit.

	Part Number	Capacitance (pF)	Clamp Voltage (V) <sup>2</sup>	Operating Voltage (VDC) <sup>3</sup>	Leakage Current (Max nA)	Package	Lines	Input Polarity	ESD Protection Level <sup>(1)</sup>
MLA	V5.5MLA0402	220	19 at 1A	0–5.5	<5	0402	1	Bi-polar	8kV
	V5.5MLA0603	660	19 at 2A	0–5.5	<25	0603	1	Bi-polar	8kV
	V5.5MLA0402L	70	30 at 1A	0–5.5	<5	0402	1	Bi-polar	8kV
	V9MLA0402	120	26 at 1A	0–9	<5	0402	1	Bi-polar	8kV
	V9MLA0402L	33	30 at 1A	0–9	<5	0402	1	Bi-polar	8kV
	V9MLA0603	420	28 at 2A	0–9	<25	0603	1	Bi-polar	8kV
	V9MLA0805L	450	20 at 2A	0–9	<25	0805	1	Bi-polar	8kV
	V12MLA0805L	350	25 at 2A	0–12	<25	0805	1	Bi-polar	8kV
	V14MLA0402	70	35 at 1A	0–14	<5	0402	1	Bi-polar	8kV
	V14MLA0603	150	40 at 2A	0–14	<25	0603	1	Bi-polar	8kV
	V14MLA0805	480	30 at 5A	0–14	<25	0805	1	Bi-polar	8kV
	V14MLA0805L	270	30 at 2A	0–14	<25	0805	1	Bi-polar	8kV
	V18MLA0402	40	46 at 1A	0–18	<5	0402	1	Bi-polar	8kV
	V18MLA0603	100	46 at 2A	0–18	<25	0603	1	Bi-polar	8kV
	V18MLA0805	450	40 at 5A	0–18	<25	0805	1	Bi-polar	8kV
	V18MLA0805L	250	40 at 2A	0–18	<25	0805	1	Bi-polar	8kV
MLE	V18MLE0402	40	50 at 1A	0–18	<5	0402	1	Bi-polar	8kV
	V18MLE0603	100	50 at 2A	0–18	<25	0603	1	Bi-polar	8kV
	V18MLE0603L	60	50 at 1A	0–18	<25	0603	1	Bi-polar	8kV
	V18MLE0805	500	50 at 5A	0–18	<25	0805	1	Bi-polar	8kV
	V18MLE0805L	100	50 at 2A	0–18	<25	0805	1	Bi-polar	8kV
MLN	V5.5MLN41206	430	19 at 2A	0–5.5	<5	1206	4	Bi-polar	8kV
	V9MLN41206	250	28 at 2A	0–9	<5	1206	4	Bi-polar	8kV
	V14MLN41206	140	40 at 2A	0–14	<5	1206	4	Bi-polar	8kV
	V18MLN41206	100	50 at 2A	0–18	<5	1206	4	Bi-polar	8kV
	V18MLN41206L	45	50 at 1A	0–18	<5	1206	4	Bi-polar	8kV
MHS	V0402MHS03	3	160 at 1A	0–42	<0.5 at 15V	0402	1	Bi-polar	8kV
	V0402MHS12	12	70 at 1A	0–18	<5 at 15V	0402	1	Bi-polar	8kV
	V0402MHS22	22	40 at 1A	0–9	<1 at 5.5V	0402	1	Bi-polar	8kV
	V0603MHS03	3	160 at 1A	0–42	<0.5 at 15V	0603	1	Bi-polar	8kV
	V0603MHS12	12	70 at 1A	0–18	<5 at 15V	0603	1	Bi-polar	8kV
	V0603MHS22	22	40 at 1A	0–9	<1 at 5.5V	0603	1	Bi-polar	8kV

1. Minimum ESD withstand voltage, tested according to IEC 61000-4-2, level 4 (Contact Discharge).

2. Clamp Voltage using 8/20µS waveform.

3. LEAKAGE CURRENT AT MAX OPERATING VOLTAGE UNLESS OTHERWISE STATED.

## ESD Suppressor Product Selection Guide (continued)

### XTRME-GUARD AND PULSE-GUARD® POLYMER ESD SUPPRESSORS

XTRME-GUARD and PULSE-GUARD Polymer ESD Suppressors offer extremely low capacitance for use in high-speed data circuits (IEEE 1394, USB 2.0, USB3.0, HDMI, DVI, etc.). Available in single-line and multi-line packages, they provide ESD protection while ensuring that signal integrity is maintained. The XGD Series XTREME-GUARD™ ESD Suppressor provide surge rating up to 30kV while adding virtually no capacitance to the circuit, which helps preserve signal integrity and minimize data loss. It is suitable for high voltage applications up to 32VDC.

Part Number	Capacitance (pF)	Clamp Voltage (V)	Operating Voltage (VDC)	Leakage Current (Max nA)	Package	Lines	Input Polarity	ESD Protection Level <sup>(1)</sup>
PGB2010201	0.07	55	0-12	1	0201	1	Bi-polar	8kV
PGB1010402	0.04	250	0-12	1	0402	1	Bi-polar	8kV
PGB2010402	0.07	40	0-12	1	0402	1	Bi-polar	8kV
PGB1010603	0.06	150	0-24	1	0603	1	Bi-polar	8kV
PGB102ST23	0.12	150	0-24	1	SOT23	2	Bi-polar	8kV
XGD10402	0.04	40	0-24	1	0402	1	Bi-polar	30kV
XGD10603	0.09	40	0-32	1	0603	1	Bi-polar	30kV

A robust web-based tool to help circuit designers identify the optimal electronic fuses for their products.



To use the Littelfuse iDesign tool, simply register to create a free online account at the [iDesign Login](#).

Free app allows circuit designers to narrow their circuit protection device options quickly and easily



## Legal Disclaimers

### Liability

Littelfuse, Inc. its affiliates, agents, and employees, and all persons acting on its or their behalf (collectively, "Littelfuse"), disclaim any and all liability for any errors, inaccuracies or incompleteness contained here or in any other disclosure relating to any product. Littelfuse disclaims any and all liability arising out of the use or application of any product described herein or of any information provided herein to the maximum extent permitted by law. The product specifications do not expand or otherwise modify Littelfuse terms and conditions of purchase, including but not limited to the warranty expressed therein, which apply to these products.

### Right to Make Changes

Littelfuse reserves the right to make any and all changes to the products described herein without notice.

### Not Intended for Use in Life Support or Life Saving Applications

The products shown herein are not designed for use in life sustaining or life saving applications unless otherwise expressly indicated. Customers using or selling Littelfuse products not expressly indicated for use in such applications do so entirely at their own risk and agree to fully indemnify Littelfuse for any damages arising or resulting from such use or sale. Please contact authorized Littelfuse personnel to obtain terms and conditions regarding products designed for such applications.

### Intellectual Property

No license, express or implied, by estoppel or otherwise, to any intellectual property rights is granted by this document or by any conduct of Littelfuse. Product names and markings noted herein may be registered trademarks of their respective owners. Littelfuse makes no representations or warranties of non-infringement or misappropriation of any third party intellectual property rights unless specifically provided for herein.

### Disclaimer

Specifications, descriptions and data contained in this document are believed to be accurate. However, users should independently evaluate each product for the particular application. Littelfuse reserves the right to change any information contained herein without notice and may, at its sole discretion, change the design, manufacture or construction of any product. Visit [www.littelfuse.com](http://www.littelfuse.com) for the most up-to-date information. Littelfuse's only obligations for any of its products are specified in its Standard Terms and Conditions and Littelfuse shall not be liable for any indirect, consequential or incidental damages from any sale or use of any of its products.



Expertise Applied | Answers Delivered

[littelfuse.com](http://littelfuse.com)  
[circuitprotection@littelfuse.com](mailto:circuitprotection@littelfuse.com)